

38000 Ball valve of carbon steel with stem extension
 DN 25 - 300

06.02.2007

Operation

Högfors welded ball valve is a tight on-off valve suitable for liquid and air pipe systems. This valve is used amongst others in district heating networks and in industry. Ball valve with stem extension can be pre-insulated and installed underground.

Nominal pressure PN 40 DN 25 - 50, PN 25 DN 65 - 300
Tightness class ISO 5208, EN 12266-1 RATE A

Operating temperature max +200°C/ min -20°C

The max pressure difference depends on the working temperature

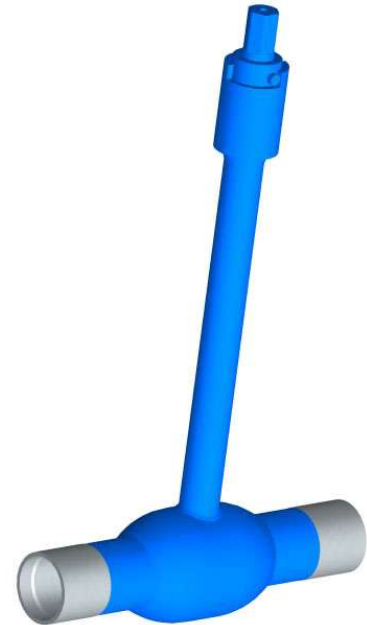
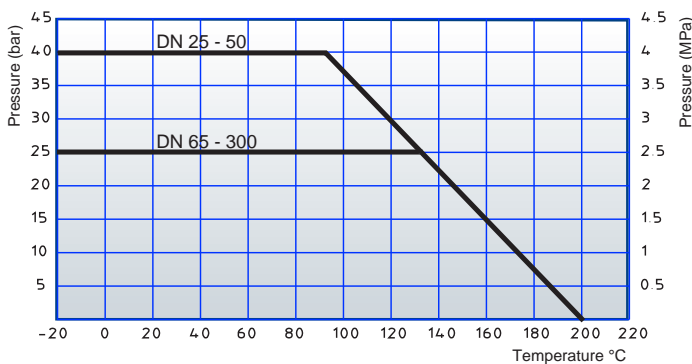

Construction

Högfors ball valve 38000 has weld ends and a body of carbon steel. Floating ball and blow-out proof stem are made of stainless steel. Ball sealing is of PTFE+C. Stem has O-rings.
 DN 25 - 150 to be operated with T-wrench, DN 200 - 300 with planet gear.

Conform with the requirements of the Council Directive 97/23/EC on Pressure Equipment, marking:
 Class: Gas, group 2



Nominal dimensions: DN 25 - 300

Product codes: 38000TR__Z with bare shaft

Materials

- Body: EN 10216-2 P235GH, DIN 17175 ST35.8
- Ball: DIN 17457 1.4301
- Stem: EN 10088-3 1.4305
- Seal: PTFE+C
- Stem seal: EPDM

38000

Ball valve of carbon steel with stem extension
DN 25 - 300

06.02.2007

Dimensions DN 25 - 150

DN	PN	Kv ₁₀₀	d	D	s	s1	D1	L	C	M	J	K	H	I	6k	Weight kg
25	40	25	20	33,7	3,2	2,3	48,3	230	43	65	302	350	374	28	19	3
32	40	41	24	42,4	3,6	2,6	60,3	260	43	65	299	350	376	28	19	3
40	40	65	31	48,3	3,6	2,6	76,1	260	43	65	304	350	390	28	19	3
50	40	100	39	60,3	4,0	3,2	88,9	300	43	65	306	350	396	28	19	4,5
65	25	180	50	76,1	4,5	3,2	101,6	300	43	62	303	350	402	28	19	7
80	25	270	65	88,9	4,0	3,2	127,0	300	43	62	302	350	413	28	19	8
100	25	420	80	114,3	6,3	3,6	159,0	325	55	82	295	350	431	35	27	12
125	25	650	100	139,7	6,3	3,6	193,7	325	55	82	293	350	445	35	27	17
150	25	950	125	168,3	6,3	4,0	244,5	350	55	80	291	350	472	35	27	31

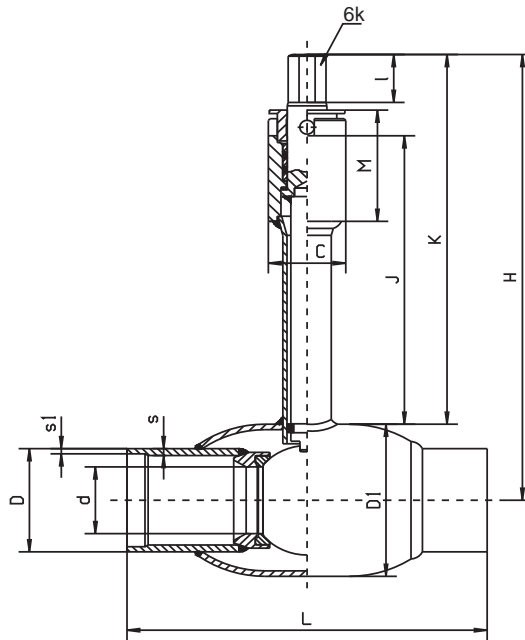

Dimensions DN 200 - 300

DN	PN	Kv ₁₀₀	d	D	s	D1	L	D2	K	H	a	Weight kg
200	25	1700	150	219,1	6,3	273	400	76,1	395	532	150	48
250	25	2600	200	273,0	6,3	368	530	88,9	373	557	175	89
300	25	4500	250	323,9	7,1	445	550	88,9	510	733	210	148

