

## CV32D Product Manual

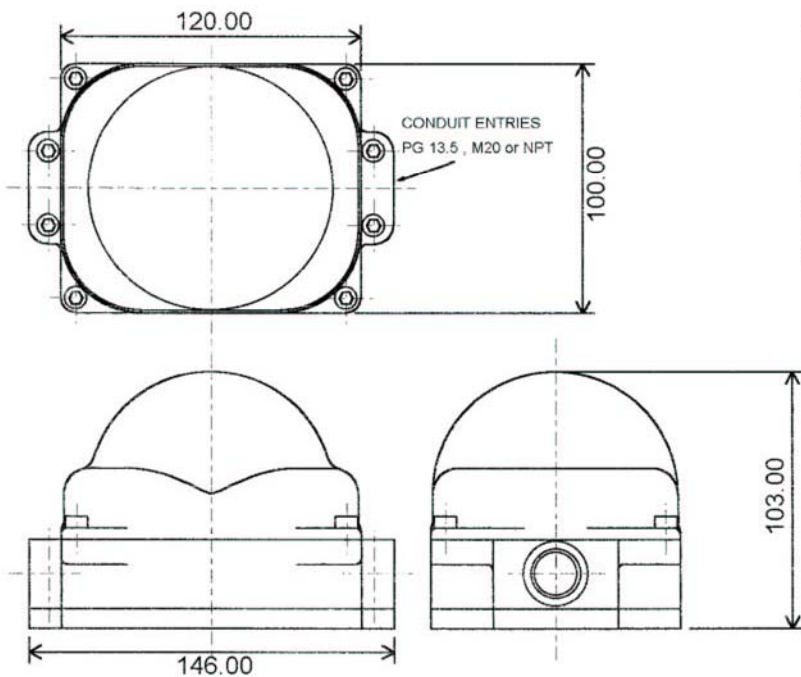

### Overall Dimensions



### Materials of Construction

Enclosure	Polycarbonate Lexan 121
Indicator	Polycarbonate Lexan 121
Interface Plate	Polycarbonate Lexan 121
O-Ring	Nitrile
Fasteners	Stainless Steel

### View of cam adjusters

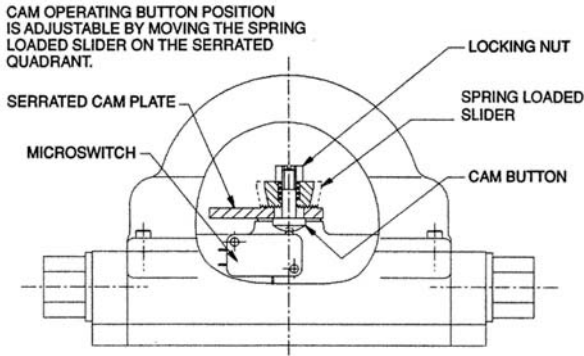

Total accessibility and simplicity provide rapid switch adjustment, once the lid and indicator dome are removed. The cam carrying sliders are spring loaded on splines, with the thumbscrew loosened the cam can be adjusted in seconds simply by lifting the slider and relocating it as required, re-tightening of the thumbscrew locks the slider in position and eliminates any possibility of creep.

## CV32 Switchbox

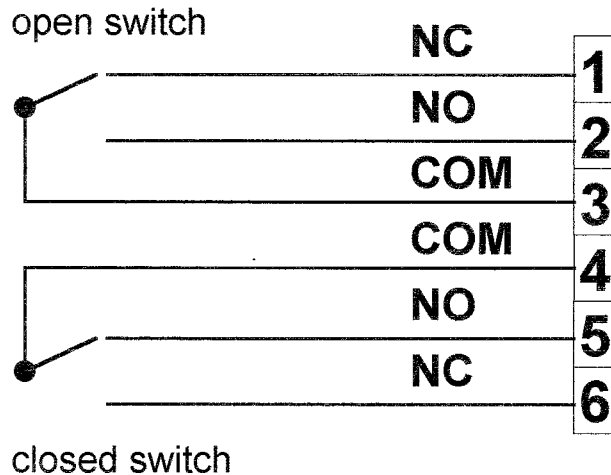

**Containing 2 V3 Micro-switches  
(Shown in closed position)**

**Wiring Diagram Ref:- WD01CV32**

SGS House,  
Johns Lane  
Tividale  
Warley  
West Midlands  
B69 3HX  
Telephone:- 0121 520 6454  
Telex:- 339118 SGSBHM  
Telefax:- 0121 522 4116

**Report No. : ES 25108**

29 October 1996

Client Ref. : 9319

Page 1 of 2

Date Received : 10/10/96

Date Tested : 16/10/96

Client : **CeeVee Ltd**  
Upper Mills Estate  
Bristol Road  
Stonehouse  
Gloucestershire GL10 2BJ

For the attention of Mr J. Apperley

**1-off Switchbox, CV3**

This document supersedes all previously issued bearing the reference ES 25108

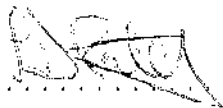
Written By :  ..... S.D.Patel  
Metallurgist.

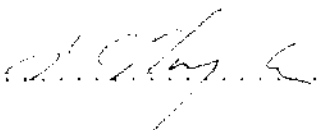
Approved By :  ..... P.G.Taylor  
Section Leader - Product Testing.

Certified that the tests have been carried out in accordance with fully documented procedures which have been Namas Accredited.  
Opinions and interpretations expressed herein are outside the scope of NAMAS Accreditation.

ALL ORIGINAL CERTIFICATION CARRIES AN EMBOSSED SEAL IN THIS SPACE.

Distribution:

- 1) Client
- 2) SGS File
- 3) -
- 4) -

**SGS****SGS United Kingdom Ltd.**  
Inspection & Engineering Services

## INTRODUCTION

The above switchbox was received for testing to BS EN 60529 IP66 and IP67.

## METHOD AND RESULTS

### IP6X Dust Ingress

The switchbox was placed in the cabinet and 50 $\mu$ m talcum powder circulated around it for 8 hours.

After 8 hours the sample was opened and inspected for ingress of dust.

There was no ingress of dust.

### IPX6 Water Ingress

The switchbox was subjected to a stream of water from a 12.5mm ID nozzle at a delivery rate of 100 l/min  $\pm$  5% from a distance of 3 metres for a period of 3 minutes per side making a total of 12 minutes.

The boxes were then dried, opened and inspected for ingress of water.

There was no ingress of water.

### IPX7 Water Ingress

The switch box was emmersed in water to a depth of 1 metre and left for 30 minutes.

After 30 minutes the switch box was removed from the water, dried, opened and inspected for ingress of water.

There was no ingress of water.

## CONCLUSIONS

The switchbox was acceptable to BS EN 60529 IP66 and IP67.